



Solution Driven.

Excellence in Cannabis Process Equipment and Technology

Backed By 60 Years of Experience

Pope, a leading manufacturer of chemical processing equipment for science and industry, is known and respected worldwide for application expertise in many processing industries including pharmaceuticals, foods, bio-materials, electronics and fine chemicals. Our USA-made equipment lines include Wiped-Film Molecular (Short-Path) Stills and Evaporators, Fractional Column Stills, Falling Film Evaporators, Reactors, Mixers, Nutsche Filter-Dryers, Crystallizers, Decarboxylators and Custom Turnkey Combined Processing Systems. Pope's cGMP & kosher certified Toll Distillation Processing Services keep us in tune with the perspective of clients' actual operations. Our in-depth process knowledge, quality standards, documentation, and customer support are continually cited as unmatched.

With Pope, you can expect exceptional cannabis process equipment, unbeatable service, and expert support for life!

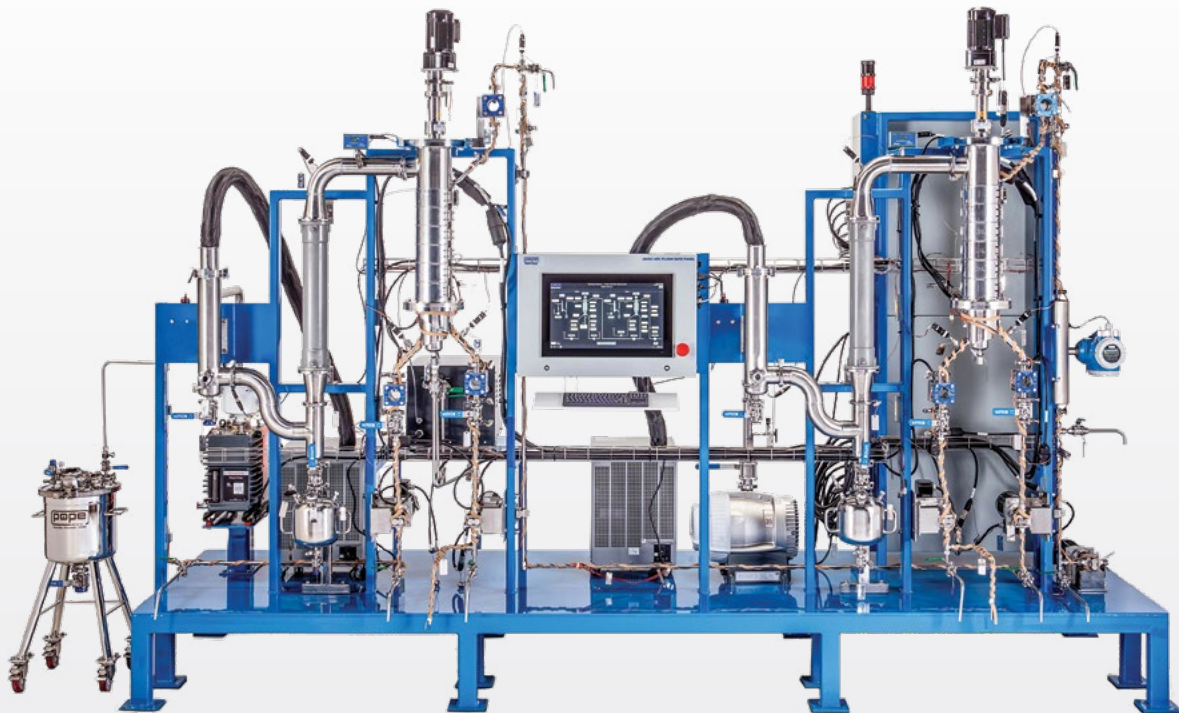

V2.0 2021

Cannabis site: www.popecannabisdistillation.com | 262-268-9300

 @popescientificinc | Main site: www.popeinc.com | Manufactured in WI, USA

Wiped-Film Molecular Distillation Equipment

Standard Packages



2" Still

- Feed Rate: 0.2 -0.7 kg/hr
- *Daily Throughput: 8-10 hr/day, 1-2 kg



4" Still w/ Feed & Discharge Pumps (optional)

- Feed Rate: 0.5 - 2.5 kg/hr
- Daily Throughput: 2-5kg



6" Still w/Feed Pump (optional)

- Feed Rate: 1-4kg/hr
- Daily Throughput: 4-12kg

**Daily throuput based on 8/10 hour day, two passes and dependent on feedstock quality and product goals.*

Additional Options:

- Jacketed Still Bodies
- Diffusion Pump
- Feed & Discharge Pump
- Feed Rate Control
- Vacuum Control
- Stainless Steel Components
- Paperless Data Recording
- Other Customizations

After extraction and winterization and decarboxylation, THC, CBD or Total Cannabinoid in extract is typically in the 60 to 70% purity range. Starting with these feed percentages, you can expect purity from mid-80s to mid-90s in percentage after two still passes using Pope distillation equipment, depending on starting material quality. Yet greater distillate purity is possible via re-distillation of distillate.

Multistage Continuous Systems

Our multistage, stainless steel, PLC-controlled, fully turnkey skid-mounted systems serve major cannabis production installations requiring capacities anywhere from 10 kg/hr up to 100 or more kg/hr. We are capable of engineering and manufacturing industrial production sized systems as large as you need. Along with the increased size and continuous operation comes the same consistency of product composition over time and sustained quality. Featuring Rockwell A-B PLC control systems with highly intuitive touch-screen operation. Plus, built-in Yokogawa data recording and logging for the best possible real time and historical data visualization, storage, transmitting and interfacing. All controls and recording are network-accessible as internal policies allow and CFR 21 part 11 compliance where required.



Isolation Equipment

Isolation Equipment for Crystallizing Cannabinoids

Crystallization is a common Isolation method used to separate a substance in its pure form from a mixture. In cannabinoid applications, crystallization is often used to isolate CBD with additional cannabinoids like THC, terpenes, and other plant components stripped out.

Under proper conditions crystals form creating a highly purified substance. Crystals will begin to nucleate when the substrate in the solvent becomes supersaturated and then process conditions can be dictated to control either nucleation or crystal growth. Most crystallization processes are done with batch reactors as it allows for precise control of these attributes, with filtering and drying performed in other equipment such as Nutsches. Pope offers a variety of equipment and turnkey solutions for crystallization.

Crystallizing Turnkey Solutions

The advantages of pairing a reactor and Nutsche Filter-Dryer include:

- Each vessel is optimally designed for performing these two different processes
- Saves time by having both processes running simultaneously
- Can be performed with no open handling of the raw material or slurry
- Isolation is a critical operation, and often the final step in the entire manufacturing process.
- Pope Scientific's Nutsches are preferred-proven for CBD crystallizing isolation to 99.9%, with less than 0.3%, to undetectable THC levels.

Pope has developed a variety of turnkey systems for creating CBD isolate, including:

- 25L Reactor and 20L Nutsche
- 50L Reactor and 40L Nutsche
- 120L Reactor and 100L Nutsche
- 200L Reactor and 170L Nutsche
- 400L Reactor and 347L Nutsche
- Custom sizes and designs available upon request



Our application engineer specialists are available to help you determine the best system for your needs.

Industry Leading Solutions for Cannabis & Hemp Processing Excellence



Nutsche Filter-Dryers

- CBD, (with THC removal), and other compound crystallization filtering.
- Jacketed for Precise Temperature Control
- Better than Buchner Funnels, ASME Certified
- ASME BPE design for pharmaceutical use



Decarboxylation Units

- ASME code vessels and turnkey systems
- Portability Available
- Aids in removal of volatiles such as ethanol while converting to active cannabinoid form.



Vessels, Reactors & Processing Systems

- Winterization & ethanol extraction systems
- Cannabinoid reaction processing, including synthetic and pharmaceutical grade
- Custom skid-mounted liquid handling, mixing, dispensing and other processing systems engineered to customer's application requirements



Hybrid Wiped-Film/Fractional Stills

- Terpene distillation
- Solvent recovery & recycling, (reduce new solvent purchase costs)
- Specialty batch and continuous distillation systems for a wide range of applications

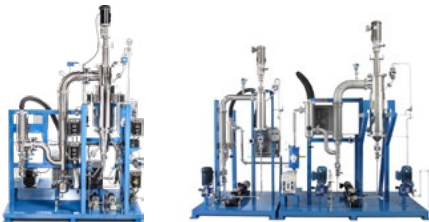

Wiped-Film Evaporators (WFE)

- Continuous solvent removal and product concentration
- Better than large rotary evaporators
- Scalable up to 200 L/hr

Falling Film Evaporators

- A good next choice when evaporation needs outgrow rotary evaporators
- A lower cost alternative to large dedicated wiped film evaporators
- Two-pass systems, FFE followed by WFE, to reduce solvent levels to < 0.1% (not possible with single pass systems).
- Reduces load and demand on subsequent decarboxylation operations

Cannabinoid Purification Distillation Process

An Inside Look at How It Works & Why It's Superior

Pope's Wiped Film Molecular Still technology incorporates several features which when combined, result in a continuous mode distillation process optimized for best performance with heat-sensitive compounds such as cannabinoids. These features include the following:

Short residence time of material fed continuously within seconds through a heated evaporation section. With batch flask methods such as "short paths" and spinning band stills, material boils for hours, resulting in greater degradation and less yield.

Short distance of molecular travel between evaporating and condensing surfaces. This is important for throughput efficiency in high vacuum distillation. With Pope's design, an internal condenser is only a few cm away, a true short path. (So-called "Short Path" stills are misnamed; the pathway is much longer, resulting in greater pressure drop, requiring greater boiling temperatures and longer times.)

Diagonally slotted, efficient rotating wiper blades. These are designed for turbulent thin film micro-mixing for high evaporation efficiency. The blades move material in both circular and downward paths for shorter, more controllable residence time and minimized product degradation. (Rollers are not as effective and can fling heavy residue to the condenser, causing coloration and lowered purity).

Continuous mode system operation, rather than batch mode. Pope Wiped-Film Molecular Stills (WFMS), can operate non-stop for extended periods of time, with any starting quantity of feed material, and with consistent product composition for the entire run.

Scalable design, with throughput linear to surface area. When greater quantities of cannabinoid material need to be processed, larger version Pope stills can be relied upon to provide predictable throughput and quality. Scalability of batch stills is poor; efficiency decreases with size.

Built-in highly versatile design. External condensers can be added to still systems to assist with greater volatile component content in feed and to partially separate groups of terpenes based on relative. These can also convert WFMS's into Wiped Film Evaporators (WFE's) for solvent removal and product concentration. Plus, easy interchangeability between electric band heating and hot oil jacket heating, and between glass and stainless steel construction. Great versatility – only from Pope.

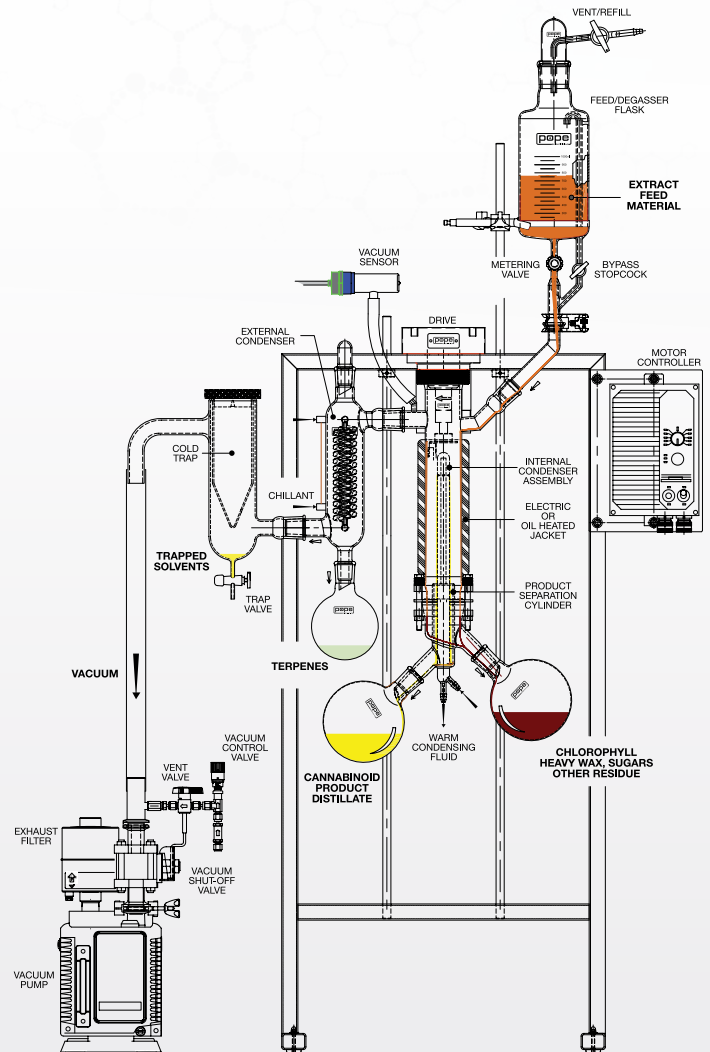

Cannabinoid Purification Distillation Process

Wiped-Film Still technology takes advantage of the fact that each chemical substance has a characteristic vapor pressure at a given temperature – a measure of volatility. Components having greater vapor pressure (lighter) are more readily evaporated from the heating surface and sent to the condensers to exit as distillate, while the lower vapor pressure (heavier) components exit the still as residue. Greater temperatures result in greater percentages of distillate (split) being collected. Skillful adjustment of temperature, vacuum level, feed rate and other parameters by the operator in processing can optimize results, based on extract composition and on desired product goals.

As is typical of almost all WFMS applications, two (or more) still passes are required for proper cannabinoid distillation. In order for cannabinoids to be distilled away efficiently from heavier undesired residues (chlorophyll, heavy lipids, sugars, etc.), and with high vacuum, throughput, yield, quality and clarity, it is important that the feed into that pass, (pass 2), should contain no volatiles (terpenes or solvents). In order to produce such material for pass 2 feed, extract must previously be processed in pass 1 to distill all terpenes (and any solvents and gases) away. Thus, two passes through a still, (or a single pass through a still system with two stills in series) is necessary for best results. This in turn assumes that nearly all ethanol or other solvents, water, etc., have already been removed (to < 0.1%) prior to pass 1. If this is not possible for whatever reason, then three (or more) wiped film still passes may be required.

When greater cannabinoid purity by distillation is desired, it is possible to re-distill the distillate. When greater yield is desired, cannabinoids left behind in stage 2 residue can be redistilled. Either of these is accomplished by a third pass through a still. There are several possible processing scenarios and Pope offers custom turnkey multi-stage system designs according to a client's specific requirements and preferences.

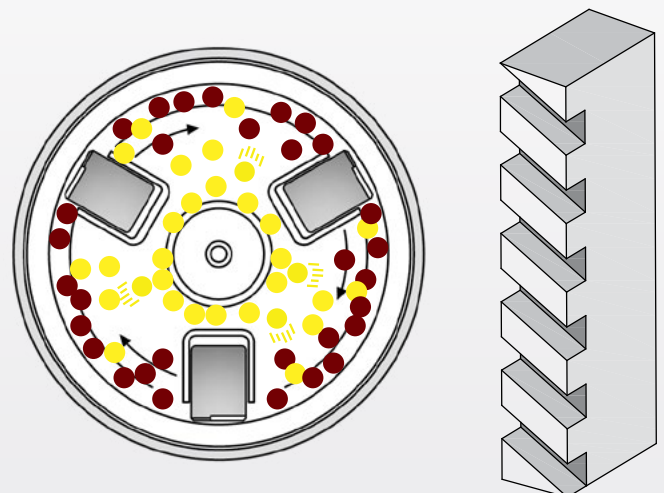
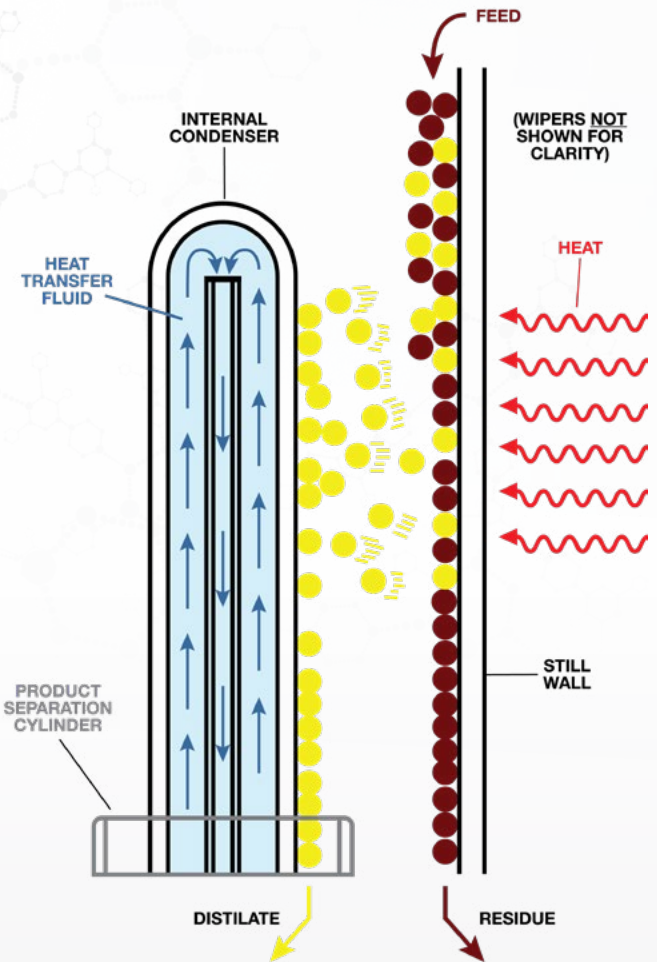



Pope Scientific, Inc

351 N. Dekora Woods Blvd.
Saukville, WI 53080

info@popeinc.com
262-268-9300
popecannabisdistillation.com
popeinc.com

For over 50 years, Pope Scientific Inc. has been at the forefront of manufacturing chemical processing equipment, engineered systems and laboratory apparatus for science and industry. Internationally known, Pope provides specialized technical expertise in the design and manufacturing of chemical processing equipment.

SOLUTIONS FOR CHEMICAL PROCESSING EXCELLENCE

Lab, Pilot & Large Scale Production Capabilities

- Wiped-Film Molecular (Short Path) Stills and Evaporators
- Batch and Continuous Fractional Distillation Systems
- Hybrid Wiped-Film / Fractional Distillation Systems
- Pressure Vessels, Reactors, and Process Vessel Systems
- Nutsche Filter – Dryers
- Sanitary / Pressurizable Mixers
- Cannabis Specialties
- Toll (Contract) Distillation, Process Development and Testing Services

POPE – WHEN PROCESS EXPERTISE AND SUPPORT MATTER.

